

Bottle Coolers



BST-36-HC



BST-50-HC



BST-95-HC



BST-65-HC

Model
BST-36-HC
BST-50-HC
BST-65-HC
BST-95-HC

STANDARD FEATURES

- CFC free refrigerant and foam with self contained capillary tube system
- Forced-air cooling
- Adjustable dividers
- Self-Defrosting Evaporator
- Bottle cap opener & cap catcher standard
- Certified to ANSI / NSF7 standards
- Four 1" Fixed Rollers
- **Now with LED Lighting**
- Warranty: 2 years parts and labor additional 3 years- compressor

*Not suitable for installation in a non-commercial or residential applications.

Items	Description	Items	Description
External top/side	Stainless steel	Temperature control	Solid State T-stat with Digital Display
Door	Stainless steel	Comply to standard	ETL LISTED, ANSI / NSF-7
External back	Steel painted black	Refrigerating system	Capillary tube
Cabinet internal	304 stainless steel	Refrigerant	R600a (BST-95-HC R290)
Internal floor	304 stainless steel	Temp. Range in box	34°F — 38°F
Insulation	Polyurethane (CFC free)	Evaporator/Condenser	Aluminum + Copper
Dividers	Heavy duty, Epoxy coating – 3 or 4 layers	Condensing unit	Side Mount
Lighting	LED Lighting	Doors	Sliding Doors

BOTTLE COOLERS





DETAILS AND DIMENSIONS

*Not suitable for installation in a non-commercial or residential application

BST-36-HC

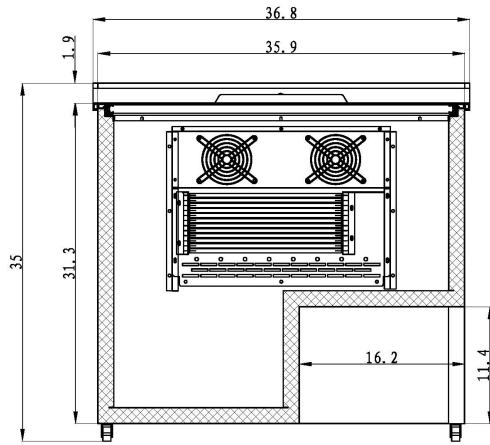

BST-50-HC

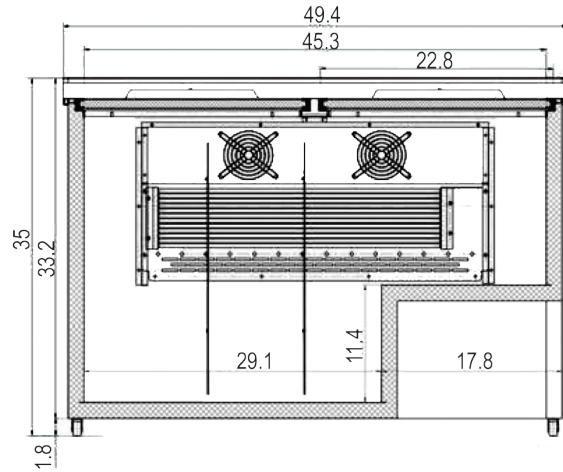

BST-65-HC

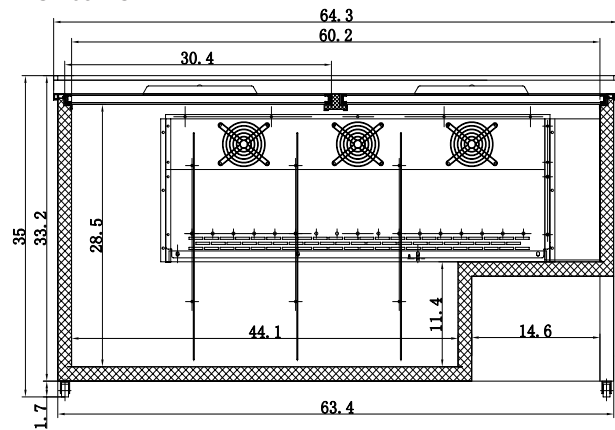

SIDE VIEW ALL MODELS

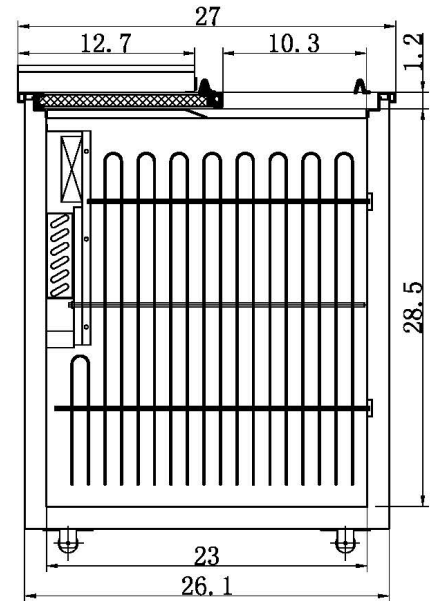

BST-95-HC

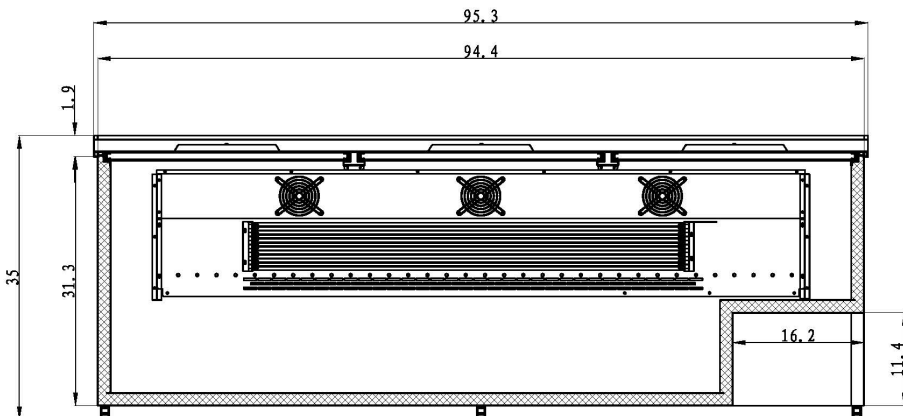

Model	# of Lids	Dividers	Cabinet Dim (in)			HP	Voltage /Hz /ph	Amp	NEMA Plug	Cord Lgth (ft)	Crated Weight (lbs)
			W	D	H						
BST-36-HC	1	-	36.8	27	35	3/8	115/60/1	1.8	5-15P	8.2	212
BST-50-HC	2	2	49.4	27	35	1/2	115/60/1	3.0	5-15P	8.2	309
BST-65-HC	2	3	64.3	27	35	1/2	115/60/1	3.0	5-15P	8.2	353
BST-95-HC	3	3	95.3	27	35	1/2	115/60/1	3.0	5-15P	8.2	439