

# Sandwich and Salad Units



Model	Size
S29-HC	29" Unit
S48-HC	48" Unit
S61-HC	61" Unit
S72-HC	72" Unit



### STANDARD FEATURES

- Solid state thermostat with digital display
- 1/6 size Lexan pans included
- Full-length poly-vinyl cutting board included
- Stainless steel front & sides
- Self closing doors remain open past 90°
- Environmentally friendly R290
- EZ slide out condenser
- Whisper quiet
- Solid construction
- Full length integrated door handle
- Casters with two front brakes
- Cool air intake
- Clearance 2" sides, 2" Rear

\*Not suitable for installation in a non-commercial or residential applications.

Items	Description	Items	Description
Front, top & sides	Stainless steel	Temperature control	Solid state thermostat/Digital display
Doors	Stainless steel / ABS liner	Approvals	ETL Listed
External back	Aluminum	Refrigerating system	Capillary tube
Cabinet interior	ABS	Refrigerant	R290
Interior floor	Stainless steel	Temperature range	34-38F
Insulation	Polyurethane (CFC free)	Evaporator	Powder coated aluminum/copper
Shelves	Heavy duty, PVC coating	Condensing unit	Rear mounted
Cutting board	Vinyl (included)		

REFRIGERATION

CONFORMS TO NSF/ANSI STD 7





# DETAILS AND DIMENSIONS

S29-HC

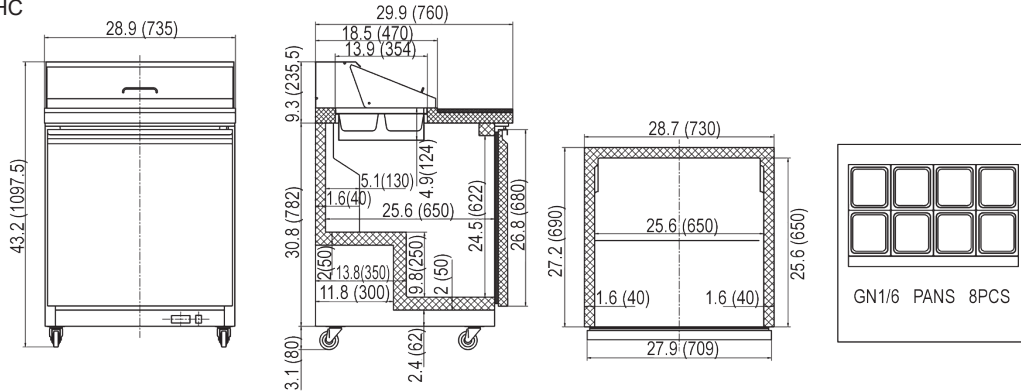

S48-HC

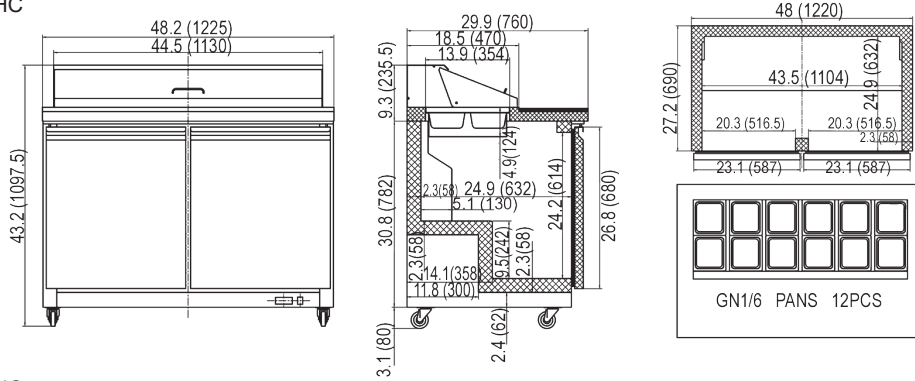

S61-HC

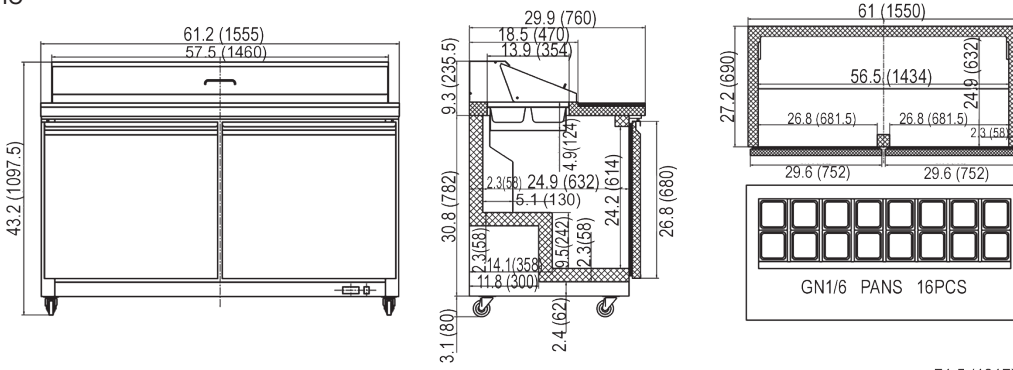

S72-HC

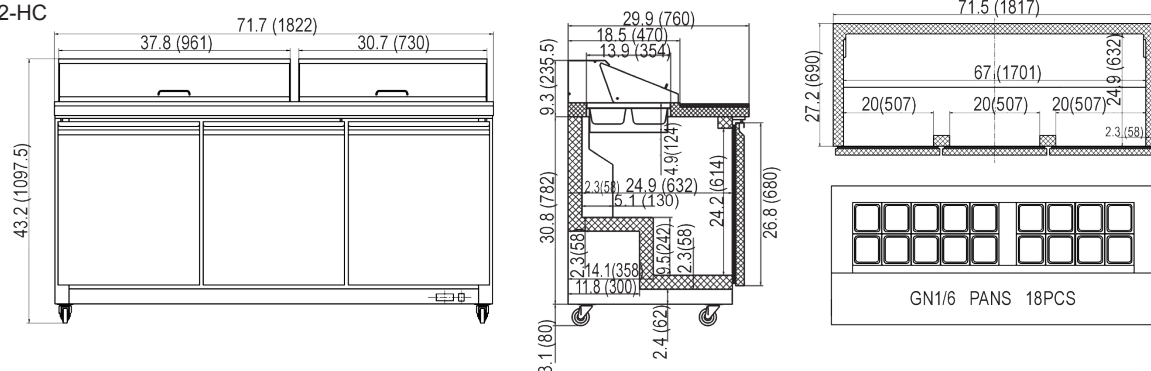

Model	Doors	Shelves	Pans	Cabinet Dim (inches)			HP	Voltage	Amps	NEMA Plug	Cord Length	Crated Weight
				L	D	H						
S29-HC	1	1	8 (1/6)	28.9	31.0	43.3	1/3	115/60/1	3	5-15P	10	276
S48-HC	2	2	12 (1/6)	48.2	31.0	43.3	1/2	115/60/1	4.3	5-15P	10	313
S61-HC	2	2	16 (1/6)	61.2	31.0	43.3	1/2	115/60/1	4.3	5-15P	10	362
S72-HC	3	6	18 (1/6)	71.1	29.9	43.2	1/2	115/60/1	4.3	5-15P	10	408